

Kepler CMOS Camera

KL400 BI

95% Peak QE, 1.6 e- Noise RMS

The Kepler KL400 provides ultra-high sensitivity, ultra-low noise with high frame rates, all at a game-changing price to performance ratio. The back-illuminated sensor is available with TVISB coating for best performance in the visible and at 240 nm; the UV version is best at 280 nm.

Technical Data

Sensor Type	Back Illuminated CMOS
Sensor	GPixel GSense400 BI
Shutter Type	Rolling
Active Pixels	2048 x 2048
Pixel Size (microns)	11 x 11 μ m
Imaging Area (Diagonal)	22.5 X 22.5 mm (31.8 mm)
Full Well Capacity	90000 electrons
Typical Readout Noise	1.6 e-
Dynamic Range	94.6 dB
Frame Rate	24 fps (Rolling HDR)
Cooling Method ¹	Air and Liquid
Max. Cooling (Air)	45°C below ambient
Temperature Stability	0.1°C
Dark Current (typical)	0.4 eps at -20C
Interface	USB 3.0 (Optional QSFP ²)
Data Bit Depth	16 bit ³
Optional Shutter	45 mm
Optional Mounts	Nikon or Canon
Subarray Readout	Standard
External Trigger In/Out	Standard
SDK / Software	Kepler / FLI Pilot
Weight	3 lbs (1.3 kg)

¹ Liquid circulation connectors sold separately

³ 16-bit data merged from two 12 bit converters

² QSFP = Quad Small Form factor Pluggable: high speed fiber optic interface



KL400 with Optional Liquid Cooling Connectors

Absolute Quantum Efficiency

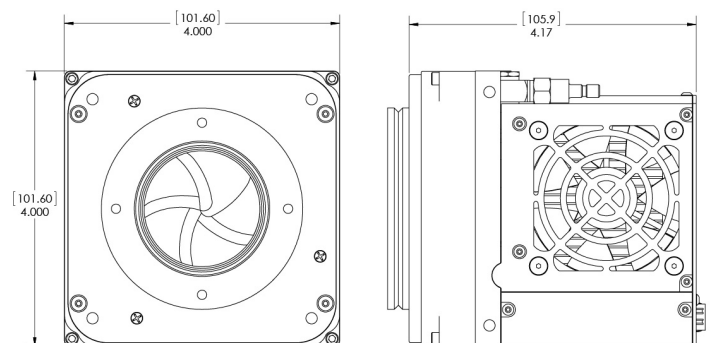
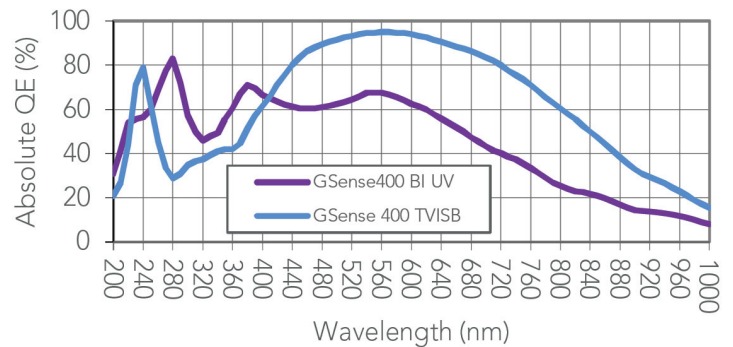

See www.flicamera.com for alternate configurations