

# DGC-300W

## Product Data Sheet

Product number: 100001214005

FULLY SWEEP  
INLINE  
PATHWAY

HIGH FLOW  
COMPATIBILITY

HIGH CAPACITY  
GAS REMOVAL

## High-Throughput Degassing for Your Fluidic System

**Improve data quality and reliability in your system with high-throughput degassing chambers from IDEX Health & Science.**

IDEX Health & Science high-flow inline degassing chambers provide superior fluid conditioning for high-throughput assay systems. Our degassing chambers improve instrument precision and assay quality by removing dissolved gases from system fluids before they outgas and form bubbles that deteriorate precision dispensing, prevent mixing, disrupt separation air gaps, or interfere with any type of fluid contact detection.

### Features:

- › Active high-capacity dissolved gas removal
- › Fully-swept inline fluid path
- › High-flow compatibility
- › Barbed fluid connection for elastomeric tubing
- › Barbed vacuum connection for elastomeric tubing
- › Sturdy housing for membrane protection

### Applications:

- › Clinical chemistry
- › Immunoassays
- › High throughput flow cytometry
- › Other high-throughput or fast flow applications

### Description

The core functional element of this inline degasser is a fluid path lined by a highly permeable silicone-like membrane. While fluid flows through the membrane-lined pathway, the space surrounding the membrane is evacuated, held at a precise vacuum level using a reliable PID-controlled IDEX Health & Science vacuum pump. The difference in gas concentration between the solution and vacuum drives the active removal of dissolved gases.

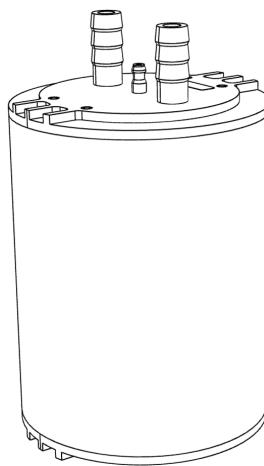

## General

Parameter	Value
Class	Degassing chamber
Series	DGC
Product alias	DGC-300W
Product number	100001214005

## Maximum Ratings (Absolute)

Parameter	Value	Unit
Maximum operating pressure difference between fluid and vacuum	100	kPa
Maximum operating flow rate	1000	mL/min
Maximum operating vacuum level	16.7	kPa
Maximum operating temperature	40	°C
Maximum operating non-condensing humidity	70	%

## Degassing

The following table contains nominal reference quantities

Parameter	Value	Unit
Degassing	Permeation through solid membrane	
Membrane material	Vinyl methyl silicone (VMQ)	
Degassing fluid volume	57	mL
Flow rate for 50% degassing efficiency	400	mL/min
Recommended minimum degassing flow rate	200	mL/min
Recommended maximum degassing flow rate	400	mL/min
Recommended degassing vacuum	16.7	kPa
Vacuum volume	408	cm <sup>3</sup>
Pumpdown period to achieve 16.7 kPa vacuum using an IDEX Health & Science double stage vacuum pump	70	s
Vacuum connection	Barb 4.9 mm OD	
Vacuum connection location	On top lid	
Vacuum connection material	Polypropylene (PP)	
Recommended vacuum connection	Low gas permeability 3 mm ID elastomeric tube	

## Regulatory

Parameter	Value
REACH	Yes
RoHS	Yes

## Fluidic

The following table contains nominal reference quantities

Parameter	Value	Unit
Internal fluid pathway	Parallel tubes	circular
Inline fluid volume	60	mL
Pressure drop-flow rate relation, flow rate q in mL/min	0.018q	kPa/mL/min
Fluid contact materials	Acrylonitrile butadiene rubber (NBR) Polypropylene (PP) Polyvinyl chloride (PVC) Vinyl methyl silicone (VMQ)	
Fluid connection	Barb 11 mm OD	
Fluid connection location	On top lid	
Fluid connection material	Polypropylene (PP)	
Fluid connection center-to-center distance	38	mm
Fluid connection edge-to-edge distance	27	mm
Recommended fluid connection	10 mm ID elastomeric tube	

## Mechanical

Parameter	Value	Unit
Housing material	Polypropylene (PP) Acrylonitrile Butadiene Styrene (ABS)	
Outer dimensions	146 x 89 x 89	mm
Mounting	Four M3x0.5 female threaded holes 5 mm deep on each lid	
Recommended mounting screw	M3x0.5	
Mounting orientation	Upright with fluid and vacuum connection pointing upward OR Horizontal with fluid and vacuum connections to the side	

## Environmental

Parameter	Value	Unit
Operating temperature	5 to 40	°C
Operating non-condensing humidity	10 to 70	%
Storage temperature	-10 to 60	°C
Storage non-condensing humidity	10 to 70	%

## Typical Performance

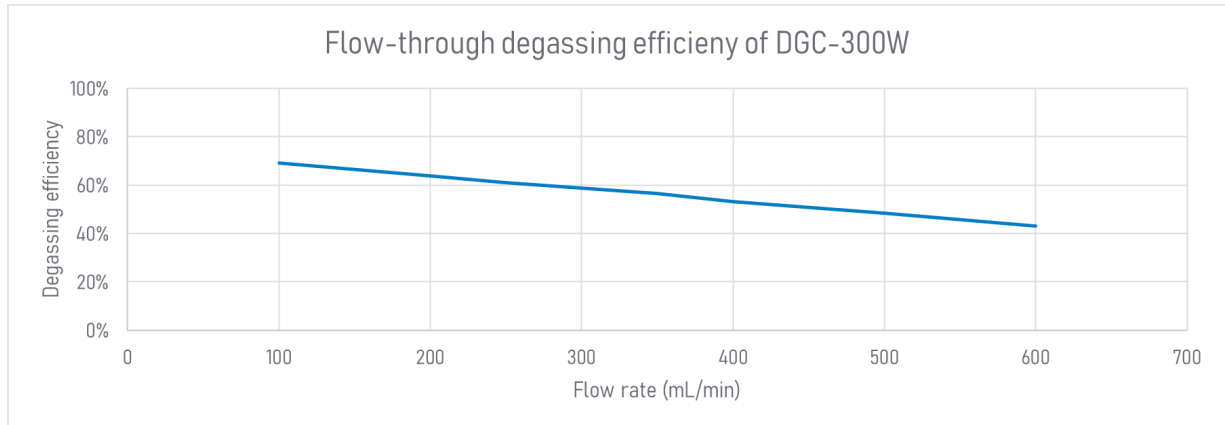
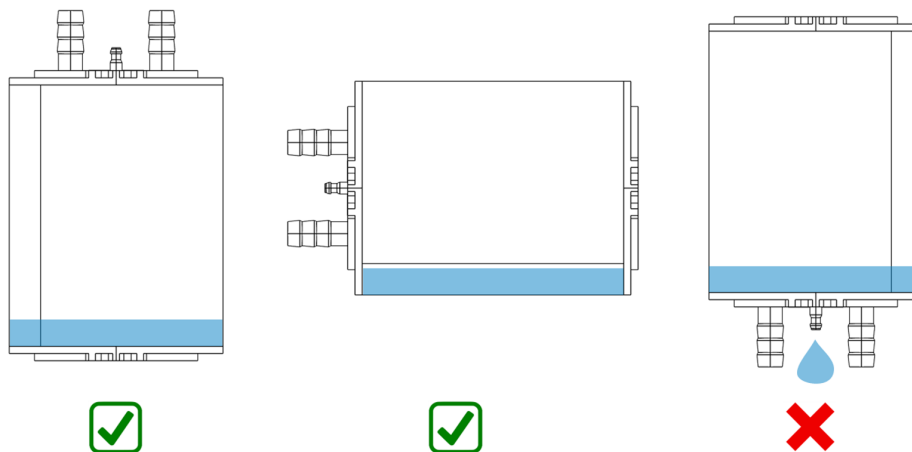

Figure 1: The plot shows the reference degassing efficiency of degassing chamber DGC-300W tested under various flow rates. The degassing efficiency represents the percentage of removed dissolved oxygen with respect to its saturation concentration. The curve shows a typical minimum performance profile gained at 25 °C using deionized water and a vacuum level of 16.7 kPa. The chamber was operated with negligible back pressure connected to the discharge side of a continuous pump. Oxygen content was monitored using a dissolved oxygen sensor while the flow rate was measured using a mass flow meter.

## Mounting Orientation

Condensation will reach an equilibrium in the chamber such that a small amount of water will be present at the bottom of the vacuum space. We recommend that the DGC-300W be mounted either in an upright position with fluid and vacuum connections pointing upward or horizontally with fluid and vacuum connections pointing sideways to avoid liquid entering the vacuum line.



## Integration

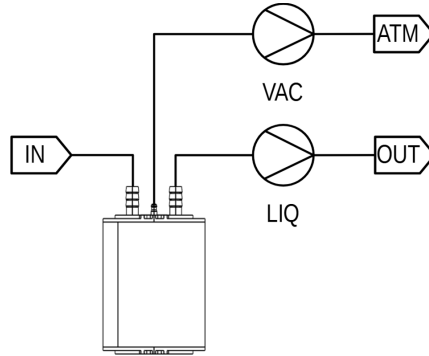

## Dimensions

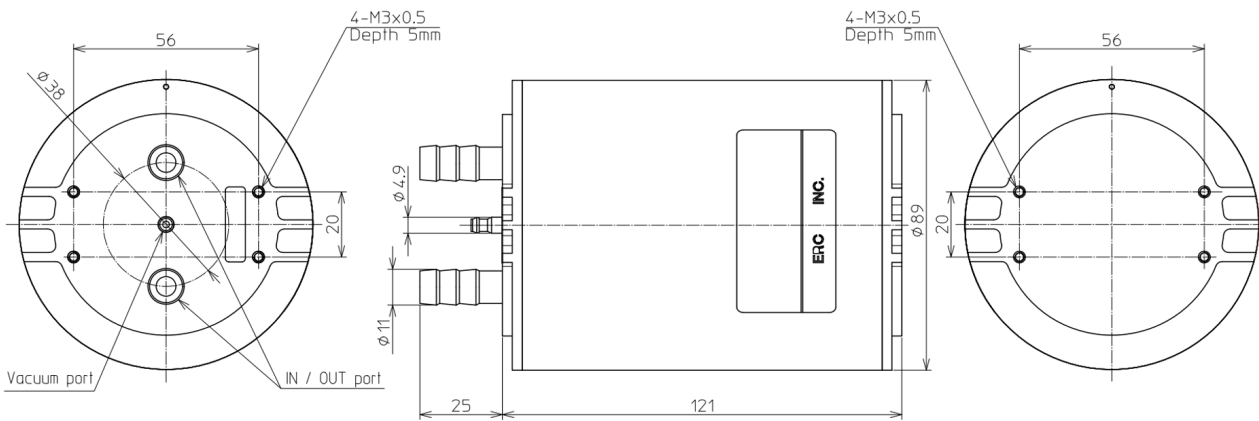

## Warranty

Seller warrants to buyer that each product will be free of defects in workmanship and material for the period of 1 year. The warranty period for all products commences on the date the product is deposited by the seller with the carrier for shipment. For complete warranty details refer to IDEX Health & Science LLC terms and conditions of sale which can be found at [www.idex-hs.com/about-us/legal-notice/terms-conditions-of-sale](http://www.idex-hs.com/about-us/legal-notice/terms-conditions-of-sale).